

High Performance UHF RFID Fixed Reader



UHF Fix
Reader

Model : UF2861-POE

Size : 227x170x40mm

Weight : 1280 g

GENERAL DESCRIPTION

SID-FXRD-UF2861POE is a high performance UHF RFID fixed reader. It is designed upon fully self-intellectual property. Based on proprietary efficient digital signal processing algorithm, it supports fast tag read/write operation with high identification rate. It can be widely applied in many RFID application systems such as logistics, access control, anti-counterfeit and industrial production process control system.

FEATURES

- Self-intellectual property;
- Support ISO18000-6C(EPC C1G2), ISO18000-6B protocol tag;
- 920~925MHz frequency band(frequency customization optional);
- FHSS or Fix Frequency transmission;
- RF output power up to 30dbm(adjustable);
- 4 TNC antenna port with antenna allure-detection;
- Support auto-running, answer, trigger and real-time-inventory work mode; Tag buffer size up to 800PCS (Max. 496bits EPC length);
- Support EPC and TID inventory;
- Low power dissipation with single +9 DC power supply;
- Support RS232, RS485, TCPIP with POE optional;
- High reliability design;
- Support on-the-site firmware upgrading.
- Supports POE or POE + (Power Over Ethernet) power supply and supports 12V-48V DC voltage transformer power supply.

CHARACTERISTICS

Absolute Maximum Rating

ITEM	SYM BOL	VALUE	UNIT
Power Supply	VCC	16	V
Operating Temp.	T _{OPR}	-10~+60	°C
Storage Temp.	T _{STR}	-20~+75	°C

Electrical and Mechanical Specification

Under T_A=25°C, VCC=+9V unless specified

ITEM	SYM BOL	MIN	TYP	MAX	UNIT
Power Supply	VCC	8	9	12	V
Current Dissipation	IC		800	1500	mA
Frequency	F _{REQ}	920	920~925	925	MHz
Size	Size		227x170x40		mm

MECHANICAL DATA (UNIT mm):

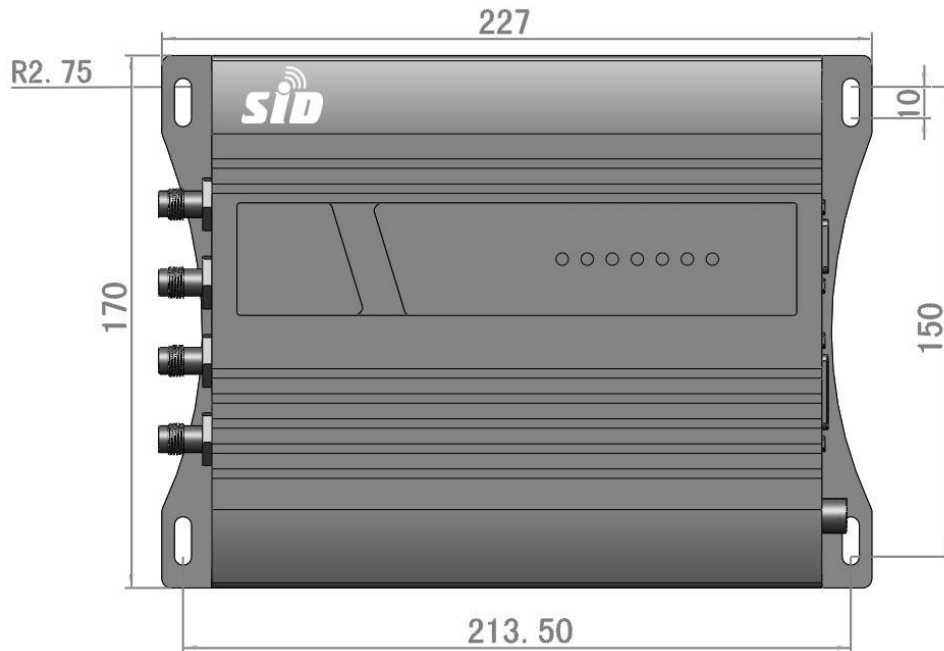

INTERFACE

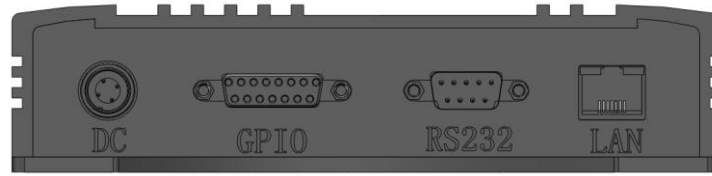

1. Power (DC JACK)

No.	Symbol	Comment
Central	PWR	+9VDC
Outer	GND	Ground

2. GPIO (DB15 Female)

No.	Symbol	Comment
1	Output1	General output1
2	Output2	General output2
3	Output3	General output3
4	Output4	General output4
5	Input1	General Input1 with Internal 47k resistor pulled-down to ground
6	Input2	General Input2 with Internal 47k resistor pulled-down to ground
7	Input3	General Input3 with Internal 47k resistor pulled-down to ground
8	Input4	General Input4 with Internal 47k resistor pulled-down to ground
9	TGIN	Trigger input with internal 10k resistor pulled-up to +5V
10	R+	R+ in RS485
11	R-	R- in RS485
12	GND	Ground
13	NC	Normal-Close terminal of internal relay
14	NO	Normal-Open terminal of internal relay
15	CM	Common terminal of internal relay

3. UART (RS232 DB9 Female)

No.	Symbol	Comment
1	NC	Reserved
2	TXD	Data output in RS232
3	RXD	Data input in RS232
4	NC	Reserved
5	GND	Ground
6	NC	Reserved
7	NC	Reserved
8	NC	Reserved
9	NC	Reserved

4. TCPIP network (RJ45)

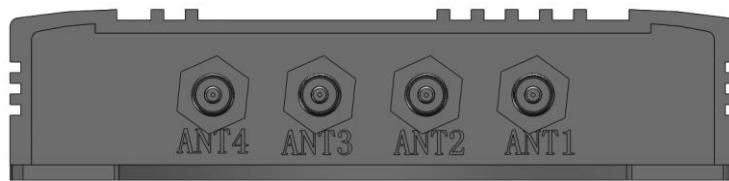

5. TNC antenna port ANT1~ANT4



6. LED indicator LED1~LED7

No.	Symbol	Comment
1	LED1	Antenna 1 active indicator
2	LED2	Antenna 2 active indicator
3	LED3	Antenna 3 active indicator
4	LED4	Antenna 4 active indicator
5	LED5	Tag-detected indicator
6	LED6	Command-executing indicator
7	LED7	Power-on indicator

Remark:

1. Specifications are subject to change, please pay attention to our latest version.

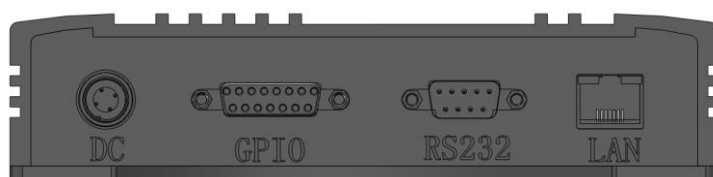

GPIO (DB15 Female)

No.	Symbol	Comment
1	Output1	General output1.The general output is used to facilitate user to control other peripheral device. The output level is 5V TTL level with 5mA current driving ability. The user can control its high or low level by sending GPIO control command.
2	Output2	General output2.The general output is used to facilitate user to control other peripheral device. The output level is 5V TTL level with 5mA current driving ability. The user can control its high or low level by sending GPIO control command.
3	Output3	General output3.The general output is used to facilitate user to control other peripheral device. The output level is 5V TTL level with 5mA current driving ability. The user can control its high or low level by sending GPIO control command.
4	Output4	General output4.The general output is used to facilitate user to control other peripheral device. The output level is 5V TTL level with 5mA current driving ability. The user can control its high or low level by sending GPIO control command.
5	Input1	General Input1 with Internal 47k resistor pulled-down to ground. The general input is used to facilitate user to get the status of other peripheral device. The input level is 5V TTL level. The user can get its value by sending GPIO control command.
6	Input2	General Input2 with Internal 47k resistor pulled-down to ground. The general input is used to facilitate user to get the status of other peripheral device. The input level is 5V TTL level. The user can get its value by sending GPIO control command.
7	Input3	General Input3 with Internal 47k resistor pulled-down to ground. The general input is used to facilitate user to get the status of other peripheral device. The input level is 5V TTL level. The user can get its value by sending GPIO control command.
8	Input4	General Input4 with Internal 47k resistor pulled-down to ground. The general input is used to facilitate user to get the status of other peripheral device. The input level is 5V TTL level. The user can get its value by sending GPIO control command.
9	TGIN	Trigger input with internal 10k resistor pulled-up to +5V. the reader supports trigger mode. The user can use this pin to trig the reader's work.
10	R+	R+ in RS485. It is the positive data of RS485 bus.
11	R-	R- in RS485. It is the positive data of RS485 bus.
12	GND	Ground
13	NC	Normal-Close terminal of internal relay. The reader has one internal built-in relay. This is the normal close terminal of it.
14	NO	Normal-Open terminal of internal relay. The reader has one internal built-in relay. This is the normal open terminal of it.
15	CM	Common terminal of internal relay. The reader has one internal built-in relay. This is the common terminal of it.